

SMT 600 w/KISS - Technical Manual

GENERAL DESCRIPTION

The SMT600 is Bartlett Instrument's fifth generation kiln controller board. It incorporates zone control features previously obtained with an add-on board and optional communication capabilities to interface with a personal computer using **KISS™** (Kiln Interface Software System). The SMT600 board is the same as its predecessor boards in many ways but it has many more options:

- ❑ The SMT600 has the same panel size so it can replace any of the current boards.
- ❑ The power requirements (24V CT Transformer) and input hookups are the same.
- ❑ Output hook-ups can be used the same as present boards but also there are many more output options with the SMT600.
- ❑ The SMT600 can be programmed to use 1, 2, or 3 thermocouples. It can replace either the current single zone board or the 3 zone board.
- ❑ The second output has increased drive over the current zone board so it can drive 3 to 4 relays.

PRECAUTIONS

This controller contains static sensitive parts, which can be damaged by static electricity. Use ground strap or touch a grounded object when handling this controller. Pack in anti-static treated material or paper. Do not pack in plastic bags or untreated packing.

This controller is a temperature regulating device not a safety device. You should attend your kiln during firings

POWER SUPPLY

The SMT600 requires a 24V center-tap transformer. It connects to the board's bottom 3 quick connects, labeled AC1, CENTER TAP, and AC2 (see [figure 1](#), page 6). The VA rating of the transformer is dependent on the electrical load of the board and relays. The board requires approximately 80mA at 12V DC and a relay typically requires approximately 140mA at 12V DC. Therefore, a three-relay system will require a transformer with a minimum rating of 6VA. (500mA X 12V DC = 6 VA)

OUTPUTS

The SMT600 has four 12V DC outputs. The four outputs are given power by a safety transistor. The safety transistor is capacitor coupled to the microprocessor so it only powers the output transistors when the microprocessor is operating correctly. Outputs 1, 2 and 3 respond to their respective thermocouple inputs. Outputs 1 and 3 can each drive a 150mA 12V DC load and output 2 can drive a 600mA 12 V DC load. Output 4 is an extra output that can be custom factory programmed to run a fan, alarm or extra section. Standard boards have output 4 come on at the beginning of a firing and off at the

SMT 600 w/KISS - Technical Manual

end of the firing to drive a safety relay. Output 4 can drive one 150mA 12V DC load. Controller manufactured after 7/99 have 5 programmable options for output 4. See “hidden other” menu for details.

HIDDEN OTHER MENU

The “hidden other” menu allows you to program the number of thermocouples, one of the five output 4 options, a PID parameter, or enter a diagnostics routine. To enter the “hidden” menu, press “other” until “rSEt” is displayed. Press “4”, “4”, “3” and “notC” will appear. Continue to press “other” to scroll through the “hidden’ options.

Hidden menu options

- notC Program number of thermocouples (formerly available by pressing “ENTER PROG”, “8”, “8”, “7”)
- OP A Output 4 on during cone fire and cooling and programmable in vary fire.
- OP b Output 4 on through the first part of cone firing and the last part of cooling. Output 4 also programmable in vary fire.
- OP C Output 4 programmable in vary fire only.
- PCt Output 4 is on a percent of output 3.
- SAft Output 4 is used to drive a safety contactor in front of the switching relay
- PId Sets the amount of help section two gives section 3 when section 3 is lagging
- dIAG Used to check if each section is connected to the right output and heating.
- SHtO For 2 and 3 zone controls when shutoff is “off”, the controller uses the average of all three t/c’s to shut off the kiln. When “on” the kiln turns off when any one of the t/c’s reaches temperature.
- ALr4 Output 4 on when the alarm triggers.

PROGRAMMING NUMBER OF THERMOCOUPLES

Selecting the number of thermocouples is the first option in the hidden menu. This allows one controller board to be used for single or multi-zone kilns. To program the number of thermocouples - press “other”, “4”, “4”, “3”. When “notC” is displayed press “ENTER” and the current number of thermocouples selected will be displayed. Press the number key representing the number of inputs (1,2 or 3). Now press “ENTER” and “CPL “ will be displayed to indicate programming is complete. When programmed for use as a multi-zone board, the display will cycle between t/c X and the temperature, where X indicates which thermocouple’s temperature is being displayed. When programmed as a single zone board, the display will not show the t/c number being read.

SMT 600 w/KISS - Technical Manual

SINGLE ZONE

Input T/C 2 is used when programmed for single zone. All three outputs work in unison so there are two alternatives for connecting the output. You can connect all the relays to the higher current output 2 or you can connect one relay to each output. The first method allows direct replacement of the current single zone controller without changing wiring. The second method would allow easy upgrade to multi-zone kilns in the future by just adding thermocouples and reprogramming the number of T/C's.

3-ZONE

Generally T/C 1 is the top thermocouple, T/C 2 is the middle, and T/C3 is the bottom. Likewise, output 1 drives the top relay, output 2 the middle, and output 3 the bottom. For taller kilns, output 2 can control several middle sections.

2-ZONE

When two thermocouples are selected, use inputs T/C1 and T/C2 and outputs 1 and 2.

OUTPUT 4 OPTIONS

One of the five options for output 4 can be selected through the "hidden" menu. To enter the "hidden" menu press "other", "4", "4", "3" then continue to press "other" until the desired option, as described below, is displayed and then press "ENTER". After "ENTER" is pressed for options A, B, C, and safety, "CPL" is displayed indicating that the option is programmed. After "ENTER" is pressed for the percent of output 3 option, the display will flash between "Pct" and the currently programmed percent waiting for a new percent to be entered.

OPTION A (OP A) Used to control a vent. Output 4 can be programmed to be on or off during each segment of a vary fire program. And, output 4 comes on at the beginning of a cone program and turns off after the kiln has cooled to 150 ° F.

OPTION B (OP b) Also used to control a vent. Output 4 can be programmed to be on or off during each segment of a vary fire program. And, output 4 comes on at the beginning of a cone fire program, off at 1450° F and back on after the firing is complete and has cooled to 1000° F and finally off again when the temperature is below 150° F.

OPTION C (OP C) Used to control a vent, an alarm or other atmospheric control. Output 4 can be programmed to be on or off during each segment of a vary fire program. Output 4 is off during cone fire programs.

SMT 600 w/KISS - Technical Manual

PERCENT (Pct) Output 4 can be programmed to be on for a percent of the time output 3 is on. To ensure output 4 stays off at all times, use this option and set the percent to 0. The percent can be set from 0 to 150.

SAFETY (SAFt) Output 4 comes on at the beginning of the firing and off at the end of the firing. This option is usually used to drive a safety contactor in front of the main switched relays.

PID (Pid) In most kilns without elements in the bottom slab, the bottom section is usually the coolest of the sections. The PID option is designed to help speed up the firing when the bottom section is cooler and lagging behind the other sections. When the bottom section is on at full power, that is, it is lagging behind, then output 2 comes on as a percent of output 1. The middle section will fire hotter and help the bottom section catch up. The percent can be set from 0 (zero) to 150. It is factory preset at 85%. When the top section is the lagging section, the PID parameter comes into play also. In this case when the top (output 1) is on full power then the center section (output 2) is on as a percent of the top. In this case the PID should probably be decreased or set to zero to even the firing.

DIAGNOSTICS (dIAG) This option is used to check each of the outputs. It will individually turn each of the three outputs on for one minute starting with the top. The display will indicate which output is on through out the test.

SHUT OFF (SHtO) For 2 and 3 zone controllers when shutoff is “off”, the controller uses the average of all three t/c’s to transition from one segment to the next or to shut off the kiln. When “on” the kiln turns off or transitions when any one of the t/c’s reaches temperature. FOR ALL DOWN RAMPS, the controller transitions from one segment to the next as if Shut Off were turned on, i. e., when any one section reaches the next segment temperature.

ALARM (Alr4) When this option is selected output 4 comes on when the alarm is triggered.

SMT 600 w/KISS - Technical Manual

TECHNICAL SPECIFICATIONS

<u>THERMOCOUPLE INPUT</u>	TYPE K (maximum resistance 100 Ohms)
<u>ACCURACY</u>	+/- 10 degrees F
<u>COLD JUNCTION COMPENSATION</u>	ELECTRONIC
<u>POWER INPUT</u>	24V CENTER-TAP TRANSFORMER
<u>OUTPUTS 1 & 3</u>	150mA at 12V; one 12 V relay with 80 Ohm coil per output
<u>OUTPUTS 2 & 4</u>	600mA at 12V; four 12 V relays with 80 Ohm coil
<u>OPERATING TEMPERATURE RANGE</u>	0 TO 125°F or 0 to 52°C

SMT 600 w/KISS - Technical Manual

CONNECTION DIAGRAM

(Figure 1)

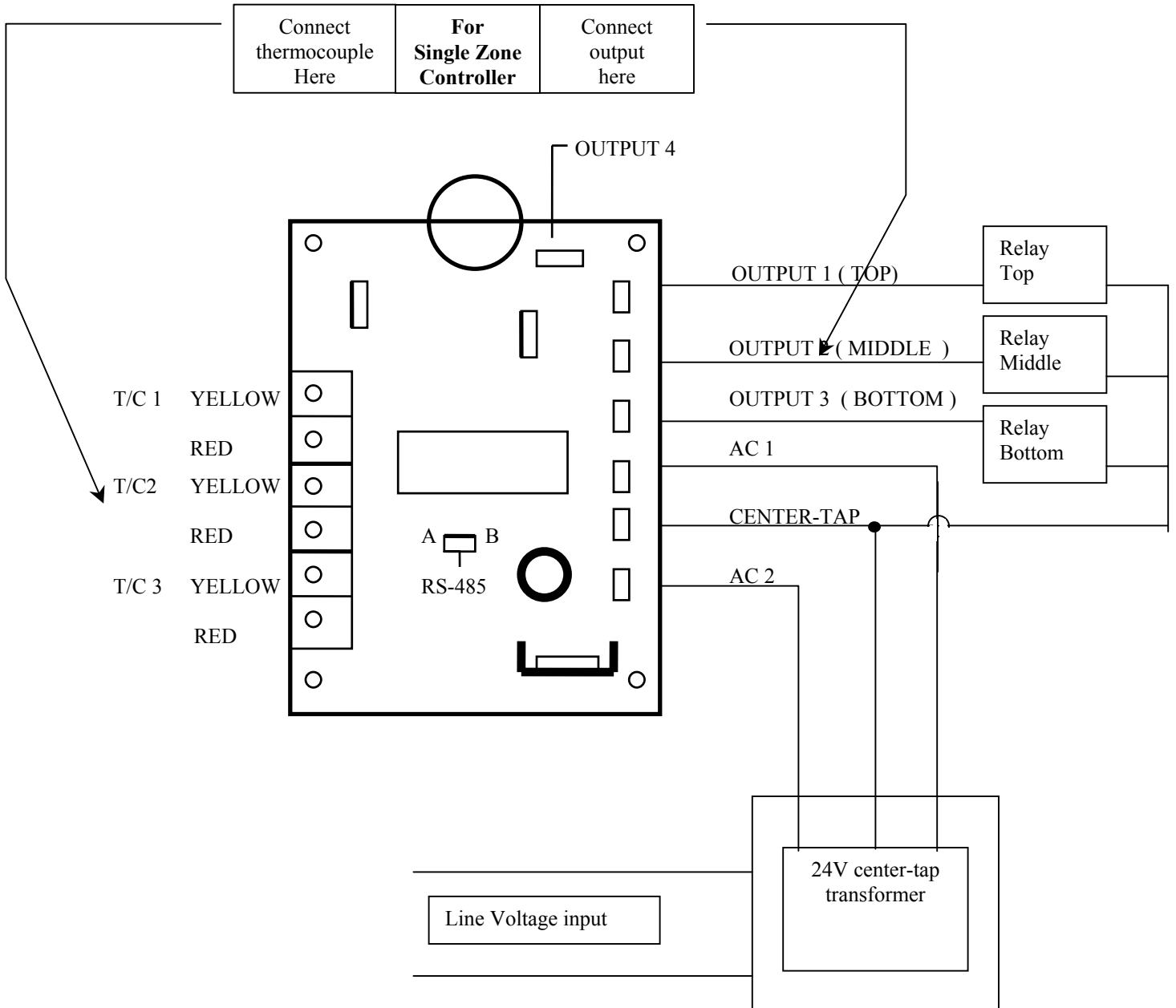

SMT 600 w/KISS - Technical Manual

KISS

KISS (Kiln Interface Software System) connects up to 10 controllers to a personal computer running Windows 95 or 98. **KISS** is an easy to use interface for programming and monitoring of the controller from a computer. During the firing, the status screen will show the current program, current set point, current segment, firing time, and each zone temperature. Firing information can also be collected in a file for later viewing or graphing.

To give your kiln a **KISS**, you need a **KISS** starter kit. For each additional kiln you connect to the network, a **KISS** kiln kit is required. The starter kit includes **KISS** software, an RS232 to RS485 opto-isolated converter with power supply, a 25 ft. modular cord, a modular wall jack to connect to the kiln, and a communications chip (integrated circuit) to insert in the controller circuit board. The kiln kit includes a 25 ft. modular cord, a modular wall jack to connect to the kiln, and a communications chip (integrated circuit), and a “T” adapter.

