

**RWL11X2 GREENHOUSE
CONTROLLER
Installation Manual**

***BARTLETT* Instrument Co.**

1404 Ave. M
Fort Madison, IA 52627
319-372-8366
www.bartinst.com

Installation Overview

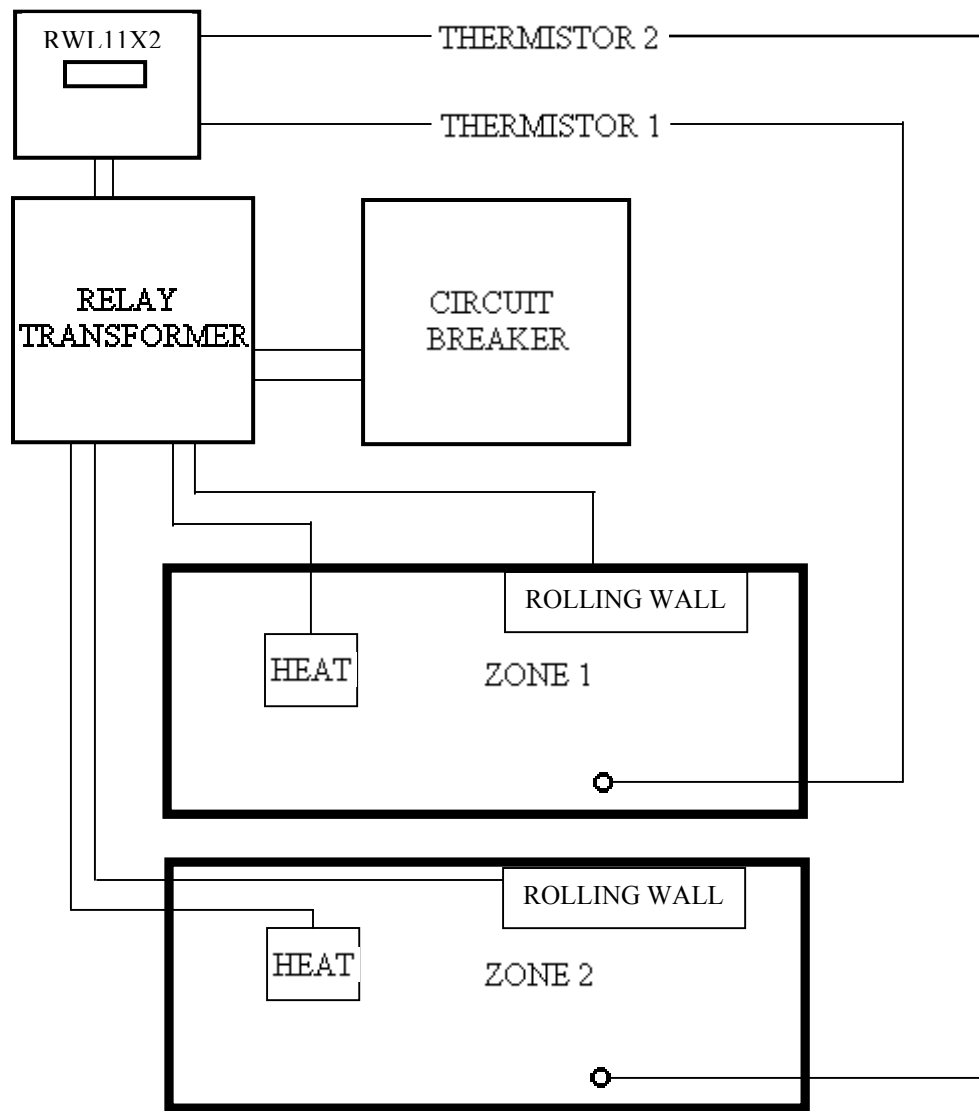

A typical installation consists of a circuit breaker box, relay/transformer box and a RWL11X2. The circuit breaker box provides overload protection. The relay/transformer box switches line power to the appliances. And, the RWL11X2 senses temperature and provides control signals.

**BE SURE ALL POWER IS OFF BEFORE
INSTALLATION!**



INSTALLATION SHOULD BE DONE BY A LICENSED
ELECTRICIAN.

BE SURE ALL WIRING AND EQUIPMENT IS
INSTALLED ACCORDING TO LOCAL ELECTRICAL
CODES.

THE RWL11X2 IS A LOW VOLTAGE DEVICE.
LIMITED TO 24V AC CONTROL VOLTAGES.

CAUTION: The RWL11X2 is designed to be reliable but as with all equipment, failures do occur. Therefore, in situations where loss could result from the failure of the RWL11X2, separate backup thermostat or alarm systems should be provided.

The reliability and performance of the RWL11X2 can be compromised by locating the controller in direct sunlight or in direct water spray.

PLACEMENT AND MOUNTING

Mount the RWL11X2 in an easy-access location. Usually close to the breaker box and relay box. Protect it from direct sunlight for better reliability and readability. Moisture can cause corrosion and premature failure, so avoid direct water and have all wire enter and leave through liquid-tight connectors, waterproof conduit, or seal the wires with silicone sealant.

WARNING: Some sealants release acetic acid while curing. Be sure sealant is completely cured (up to 3 days) before closing control box to avoid corrosion damage.

To mount the RWL11X2, remove the front cover and unplug ribbon cable from the relay board. Insert the 4 self-drilling screws provided with the RWL11X2 through the 4 screw-hole knockouts and fasten the box to the wall. Cover the screw heads with plastic cups provided. After all wiring is complete and any sealant cured, reattach the ribbon cable and screw on the front cover.

Alternately, you can mount the RWL11X2 with drywall screws placed through the corner holes of the box.

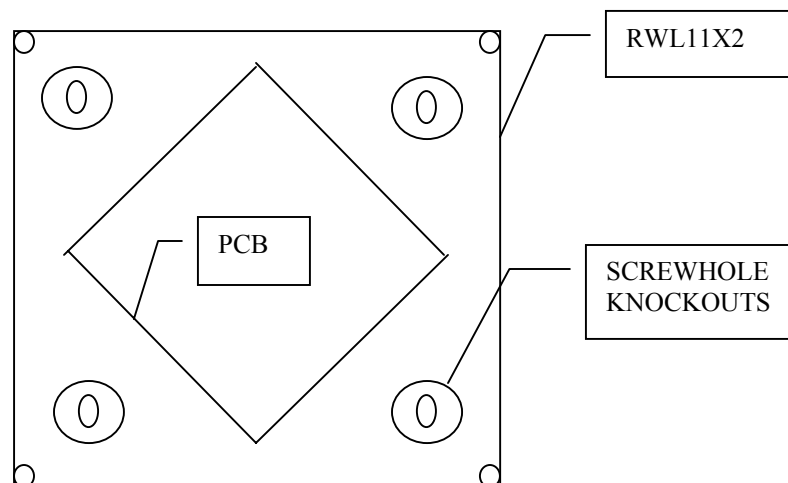

RWL11X2

OUTPUT SPECIFICATIONS

| OUTPUT | CONTACT TYPE | VOLTAGE RATING | CURRENT RATING |
|------------------------|------------------------------|----------------|-------------------|
| HEAT | DRY CONTACT OR SOURCE 24V AC | 24V AC | 2A RESISTIVE LOAD |
| OPEN CLOSE TIMER | SOURCE 24V AC | 24V AC | 2A RESISTIVE LOAD |
| ALARM | DRY CONTACT | 24V AC | 2A RESISTIVE LOAD |

All open, close, and timer outputs source 24V AC to drive a relay or contactor. The RWL11X2's drive relays are rated at 2A when driving a resistance load. For reliability snubber circuits are on each output. Also, for greater reliability, load currents on the RWL11X2's relays should be less than 1A (less than 24 VA per output).

Output Configuration

Each 24 VAC output has a contact that is common to 24VAC input line 2 (24L2) and a contact that is 24VAC line 1 switched through a relay.

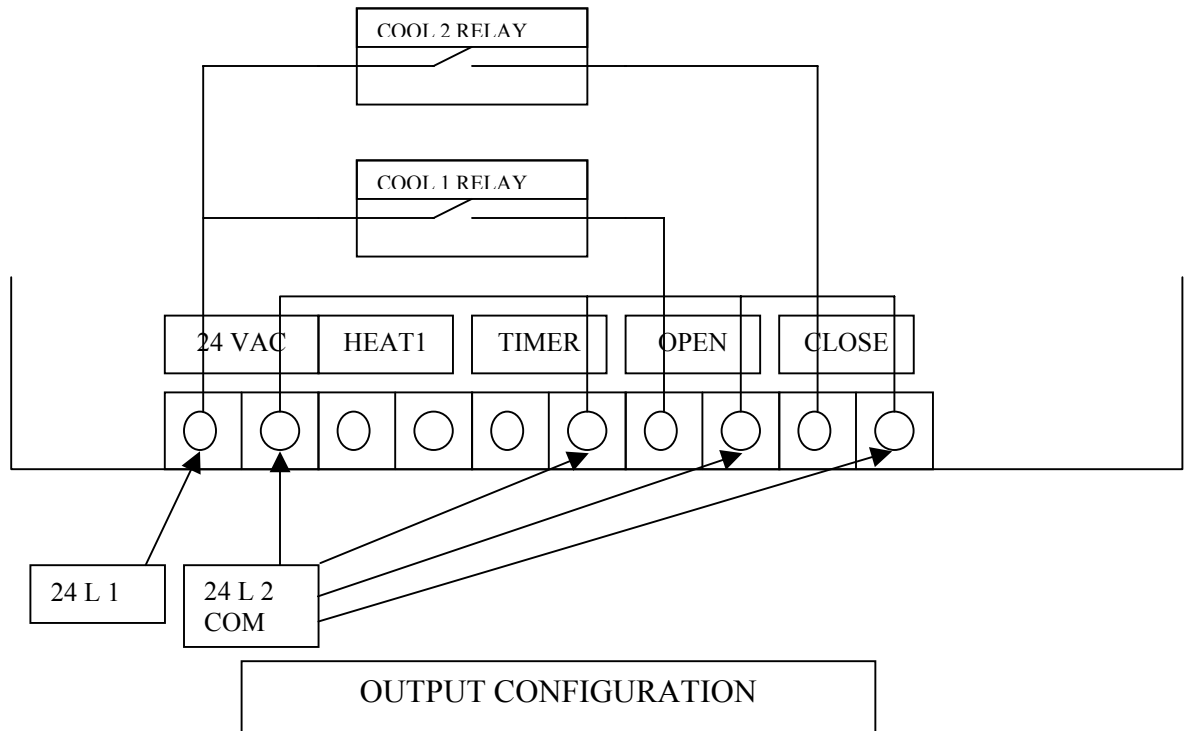

CONNECTION LOCATIONS

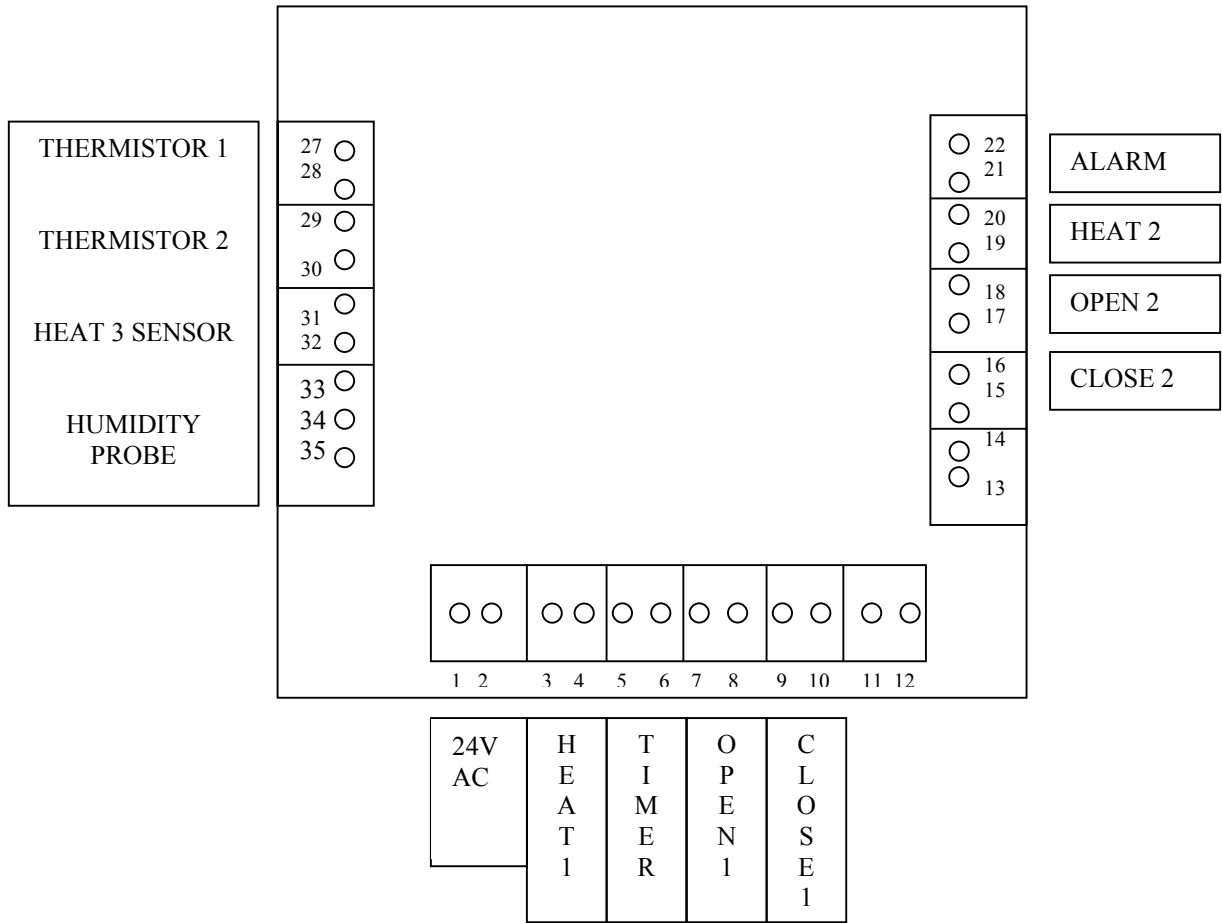

| TERMINAL | DESCRIPTION | TERMINAL | DESCRIPTION | TERMINAL | DESCRIPTION |
|----------|--------------|----------|-------------|----------|---------------|
| 1 | 24VAC L1 | 13 | | 25 | |
| 2 | 24VAC L2 COM | 14 | | 26 | |
| 3 | HEAT 1 OUT | 15 | CLOSE 2 OUT | 27 | THERMISTOR 1 |
| 4 | HEAT 1 COM | 16 | CLOSE 2 COM | 28 | THERMISTOR 1 |
| 5 | TIMER OUT | 17 | OPEN 2 OUT | 29 | THERMISTOR 2 |
| 6 | TIMER COM | 18 | OPEN 2 COM | 30 | THERMISTOR 2 |
| 7 | OPEN 1 OUT | 19 | HEAT 2 OUT | 31 | THERM. HEAT 3 |
| 8 | OPEN 1 COM | 20 | HEAT 2 COM | 32 | THERM. HEAT 3 |
| 9 | CLOSE 1 OUT | 21 | ALARM | 33 | HUM. IN |
| 10 | CLOSE 1 COM | 22 | ALARM | 34 | HUM. POWER |
| 11 | | 23 | | 35 | HUM. GROUND |
| 12 | | 24 | | | |

HEAT OUTPUTS

The heat outputs can be configured as a dry contact like a thermostat or to source 24V AC to drive a relay. Open/closed contacts is the factory setting.

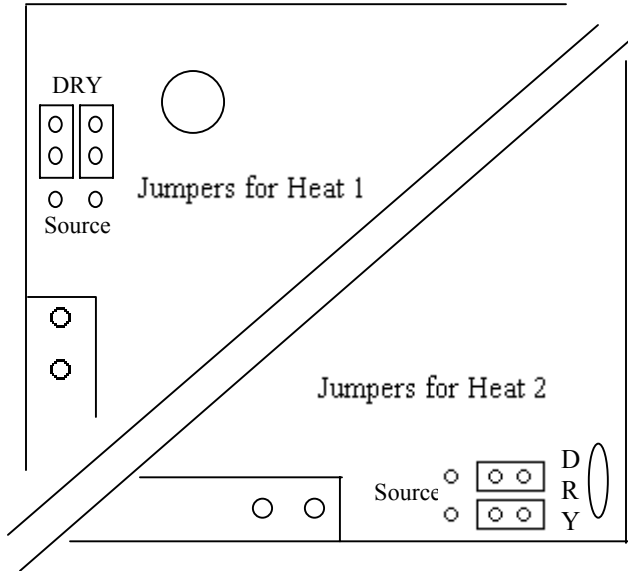

Jumpers shown for heat 1 and heat 2 are configured as OPEN/CLOSED CONTACTS.

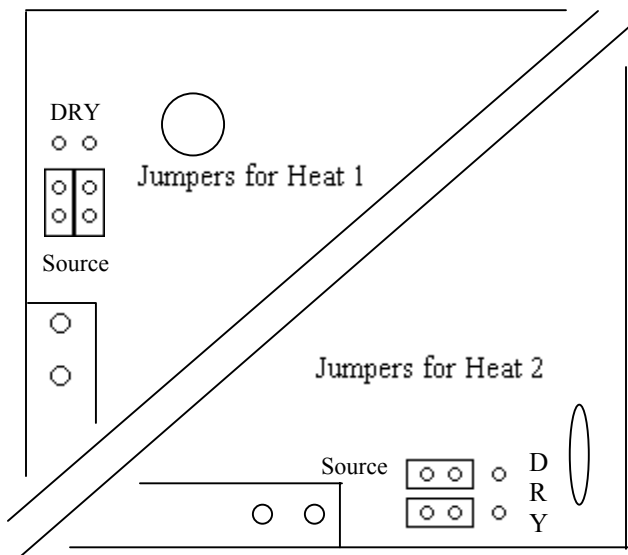

Jumpers shown for heat 1 and heat 2 are configured to SOURCE 24V AC.

HEAT OUTPUTS cont.

When controlling more than one heater from one heat output, configure the output to source 24V AC to drive a relay(s) to keep the control loops separate.

Also, when controlling a line voltage heater, configure the heat output to source 24V AC to drive a relay of sufficient capacity to run the heater.

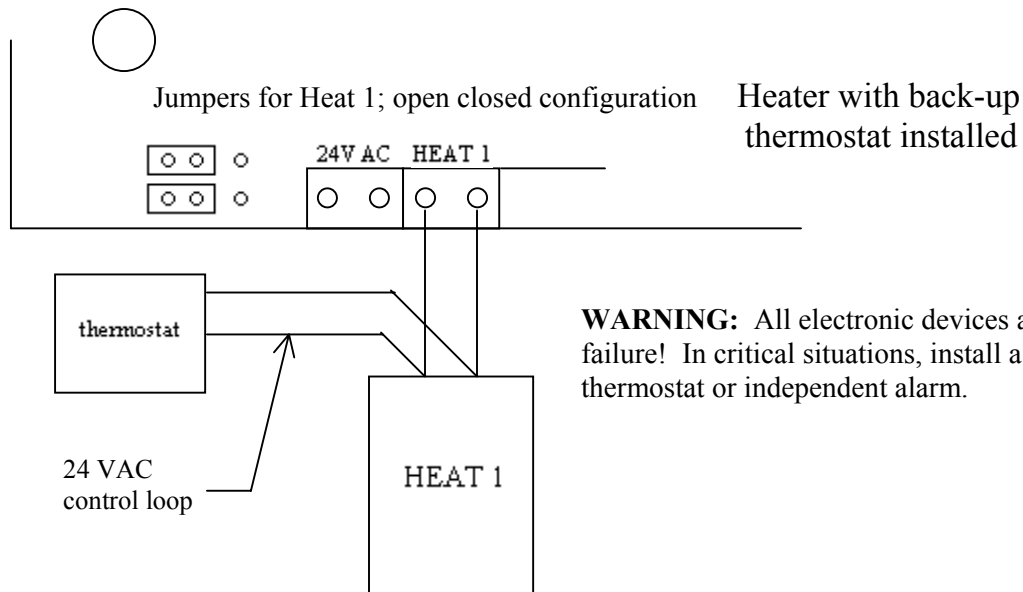
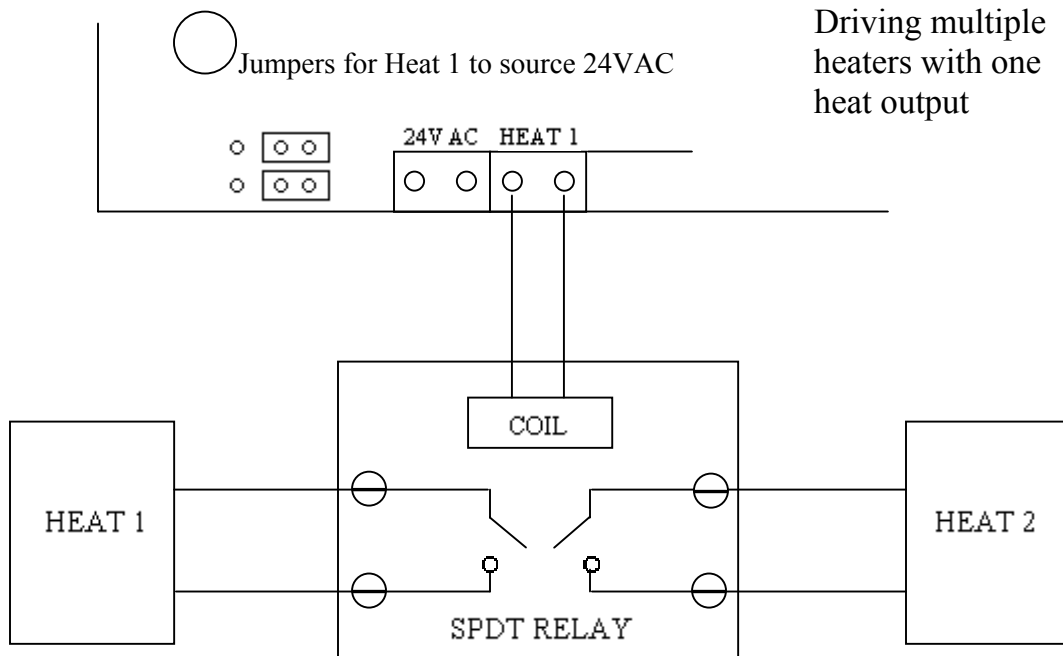

TIMER OUTPUT

The timer output sources 24V AC to drive a solenoid or relay(s). The solenoid should have a coil with less than a 24VA load.

ALARM OUTPUT

The alarm is an open/closed contact. When the RWL11X2 is powered and operating properly the contacts are CLOSED. The contacts OPEN when power is lost or when the high or low alarm is triggered.

THERMISTOR

The thermistor is the temperature sensor. The RWL11X2 has two thermistor inputs labeled TH1 and TH2. In 1-zone mode, the readings are averaged and displayed. In the 2-zone mode, heat 1 and cool 1 and cool 2 work to keep TH1 at the correct temperature. Also, heat 2 and cool 3 and cool 4 work together to keep TH2 at the desired temperature.

The thermistors should be slightly above the plant height. To ensure proper readings, it should not be in direct sunlight or where it will be sprayed with water. It is generally placed closer to the cool air inlet and further from the heat. In 1 zone mode separate the thermistors across the width of the greenhouse to give the best average temperature.

The thermistors come with 24' leads and can be connected directly to the two terminals for TH1 and to the two terminals for TH2. There is no special orientation to the thermistor leads.

Should you need to extend the leads of the thermistor, use the 3M Scotchlock™ sealed connectors provided. Use only wire size of 22-14 AWG to ensure proper connection. A faulty connection will cause erroneous temperature readings.

